

---

International Standard



272

---

INTERNATIONAL ORGANIZATION FOR STANDARDIZATION • МЕЖДУНАРОДНАЯ ОРГАНИЗАЦИЯ ПО СТАНДАРТИЗАЦИИ • ORGANISATION INTERNATIONALE DE NORMALISATION

---

**Fasteners — Hexagon products — Widths across flats**

*Éléments de fixation — Produits hexagonaux — Dimensions des surplats*

Second edition — 1982-01-15

---

UDC 621.882.1

Ref. No. ISO 272-1982 (E)

Descriptors : fasteners, screws, hexagonal head screws, bolts, nuts (fasteners), hexagonal nuts, width across flats, dimensions.

1

## Foreword

ISO (the International Organization for Standardization) is a worldwide federation of national standards institutes (ISO member bodies). The work of developing International Standards is carried out through ISO technical committees. Every member body interested in a subject for which a technical committee has been set up has the right to be represented on that committee. International organizations, governmental and non-governmental, in liaison with ISO, also take part in the work.

Draft International Standards adopted by the technical committees are circulated to the member bodies for approval before their acceptance as International Standards by the ISO Council.

International Standard ISO 272 was developed by Technical Committee ISO/TC 2, *Fasteners*. The first edition (ISO 272-1979) had been approved by the member bodies of the following countries :

Australia	Ireland	Romania
Belgium	Italy	South Africa, Rep. of
Canada	Korea, Dem. P. Rep. of	Spain
Czechoslovakia	Korea, Rep. of	Sweden
Denmark	Mexico	Switzerland
Finland	Netherlands	Turkey
Germany, F. R.	New Zealand	United Kingdom
Hungary	Norway	USA
India	Poland	Yugoslavia

The member bodies of the following countries expressed disapproval of the document on technical grounds :

France  
USSR

This second edition, which cancels and replaces ISO 272-1979, incorporates draft Addendum 1, which was circulated to the member bodies in March 1980 and has been approved by the member bodies of the following countries :

Australia	India	Poland
Austria	Ireland	Romania
Belgium	Italy	South Africa, Rep. of
Czechoslovakia	Japan	Spain
Egypt, Arab Rep. of	Korea, Dem. P. Rep. of	Sweden
Finland	Korea, Rep. of	Switzerland
France	Netherlands	United Kingdom
Germany, F. R.	New Zealand	USA
Hungary	Norway	

The member bodies of the following countries expressed disapproval of the document on technical grounds :

Canada  
Denmark  
USSR

# Fasteners — Hexagon products — Widths across flats

## 1 Scope and field of application

This International Standard specifies widths across flats for hexagon products, for example hexagon head bolts and screws, hexagon nuts and hexagon flanged bolts, screws and nuts, to be used in the respective product standards.

It also specifies a logical ratio between underhead (or nut) bearing area (which determines the magnitude of the compressive stress on the bolted members relative to the clamping force applied by the fastener) and the tensile stress area of the screw thread (which governs the clamping force which can be developed by tightening the fastener for any particular strength class of fastener). This calculation technique was applied to each of the hexagon series so that a proper grading of bearing area/stress area ratios would be available to engineering designers.

2 Dimensions

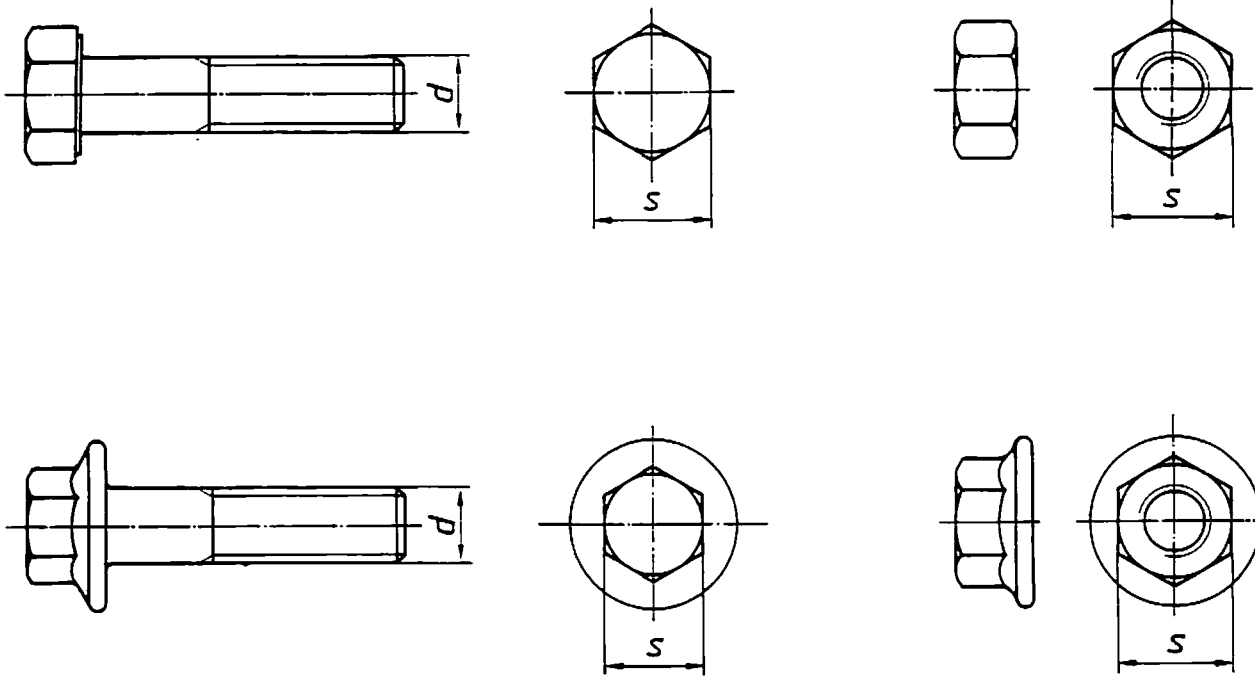

Dimensions in millimetres

Thread diameter $d$	Width across flats $s$			
	Series Normal	Series Large	Flanged products	
			Bolts	Nuts
1,6	3,2	—	—	—
2	4	—	—	—
2,5	5	—	—	—
3	5,5	—	—	—
4	7	—	—	—
5	8	—	7	8
6	10	—	8	10
7	11	—	—	—
8	13	—	10	13
10	16	—	13	15
12	18	21	15	18
14	21	24	18	21
16	24	27	21	24
18	27	30	—	—
20	30	34	27	30
22	34	36	—	—
24	36	41	—	—
27	41	46	—	—
30	46	50	—	—
33	50	55	—	—
36	55	60	—	—
39	60	65	—	—

Dimensions in millimetres

Thread diameter $d$	Width across flats $s$ normal series
42	65
45	70
48	75
52	80
56	85
60	90
64	95
68	100
72	105
76	110
80	115
85	120
90	130
95	135
100	145
105	150
110	155
115	165
120	170
125	180
130	185
140	200
150	210

### 3 Ratio of bearing area to stress area

The following graph shows the ratios for the normal, large and hexagon flange series (hexagon flange bolts and nuts have common flange diameters), in each case the across-flats dimension being shown against the appropriate point on each curve. Old hexagon sizes have also been included to indicate the changes which were found necessary in the interests of international standardization and optimization.

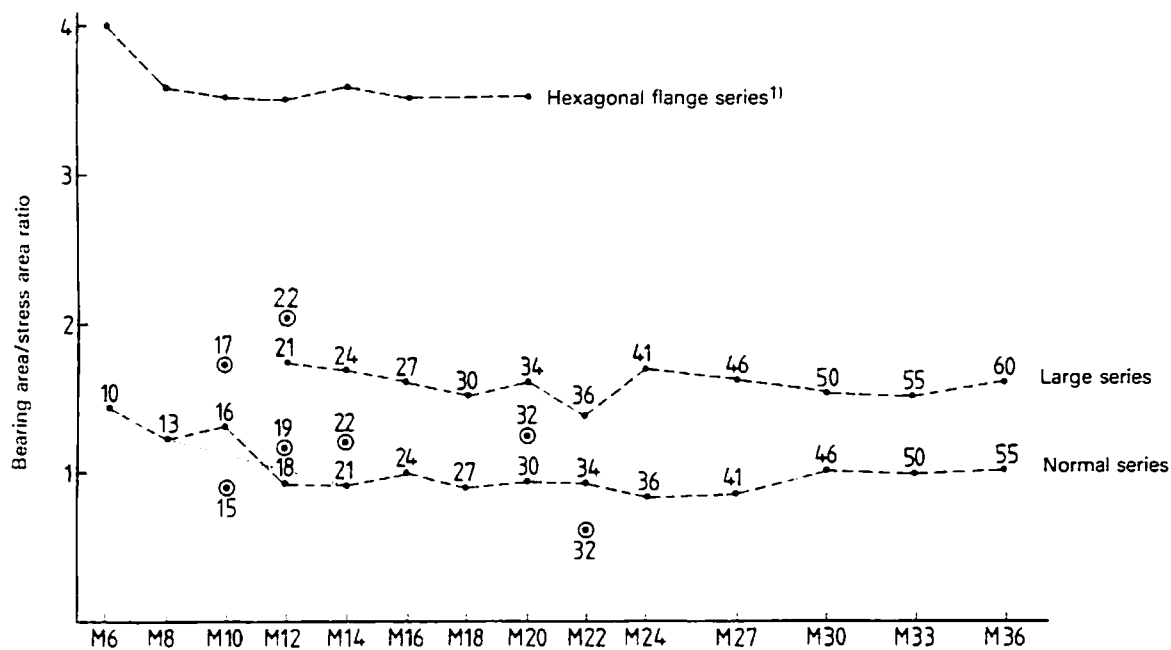

<sup>1)</sup> Still under consideration.